

LOAD MANAGEMENT EFFECT ON OPTIMUM SIZING OF STAND-ALONE HYBRID DISTRIBUTED GENERATION

Yusak Tanoto

Electrical Engineering Department, Faculty of Industrial Engineering
Petra Christian University Surabaya
tanyusak@petra.ac.id

ABSTRACT

This paper presents an optimum sizing assessment for stand-alone hybrid distributed energy system feeding a sub-village sized household community in the rural areas, affected by loading types based on demand side management principle. Simulations are carried out over the combination of hybrid power generation taking into account PV-battery, wind turbine, and diesel generator. Three loading management in which considered in this study are peak clipping, load shifting, and valley filling. Optimum hybrid generation sizing for each loading type is subject to minimum cost of energy. Besides, renewable generation fraction provided system optimum sizing is analyzed accordingly.

The simulation result reveals that the least cost of energy is achieved by load shifting scheme with USD 0.39/kWh taking into account the combination of PV-battery, wind turbine, and diesel generator. In addition, the largest renewable energy fraction obtained from load shifting type as well, accounted for 73%.

Keywords: Load Management, Optimum Sizing, Distributed Generation

ABSTRAK

Makalah ini menyajikan penentuan rating optimal dari pembangkitan listrik tersebar yang menyuplai sebuah komunitas rumah tinggal di pedesaan, yang dipengaruhi oleh variasi tipe pembebanan berdasarkan prinsip manajemen sisi permintaan. Simulasi dijalankan terhadap kombinasi jenis pembangkit listrik hibrid yang terdiri dari PV-baterai, turbin angin, dan genset. Jenis pengaturan pembebanan berdasarkan prinsip manajemen sisi permintaan yang dianalisa pada studi ini adalah peak clipping, load shifting, dan valley filling. Rating pembangkitan optimal hibrid untuk setiap jenis pembebanan ditentukan berdasarkan fungsi objektif biaya energi minimal. Selain itu, fraksi energi terbarukan yang diperoleh pada rating pembangkitan optimal untuk tiap jenis pembebanan juga dianalisa.

Dari hasil simulasi, biaya energi terendah dicapai oleh jenis pebebanan load shifting dengan USD 0.39/kWh yang terdiri dari kombinasi PV-baterai, turbin angin, dan genset. Di samping itu, fraksi energi terbarukan yang terbesar diperoleh dari jenis pembebanan load shifting pula, sebesar 73%.

Kata kunci: Manajemen Pembebanan, Rating Optimal, Pembangkitan Terdistribusi

1. INTRODUCTION

Utilization of stand-alone renewable distributed energy resources in many ways is seen as a promising method in provisioning electricity connection for people living in remote areas (Haidar et.al, 2010). Issues related with the system reliability under renewable energy resources in most cases can be negligible since either energy storage or hybrid system involving conventional non-renewable technologies can be added up as complement to the initial system. Although development of hybrid distributed generation plants are currently technically and economically viable, the cost of energy of a distributed generation system is generally higher than that obtained by bulk generation system. Several optimization methods have been successfully applied to optimize the component sizing and in the same time reduce the associated cost of the hybrid distributed system (Hongxing et.al, 2009). However, the sizing optimization is normally performed for the base case loading condition and therefore it may be changed for any other loading conditions. In addition to system size changing, the associated cost of energy and the environmental impact may be changed as well.

Loading variation shall be directed so that electricity energy can be generated and consumed in an efficient way. In order to achieve this condition, loading pattern can be preconditioned following demand side management loading principle under which load is managed so that the loading pattern can be beneficial to the technical as well as economical point of view.

2. LITERATURE REVIEW

The concept of Demand Side Management (DSM) was first introduced by Gellings and Chamberlin in 1987. DSM includes systematic activities carried out by electricity companies and government designed to change the amount and / or time of use electricity on the customer side including the use of energy efficient appliances (Gellings and Chamberlin, 1987). DSM has two main objectives that are interrelated. First, to reduce peak load requirements so that additional generating capacity can be avoided. The second objective is to reduce electricity use to solve the energy problem by changing the number and pattern of electrical energy consumption (Surapong, 2000). Six goals of DSM activities related to the electrical loading are shown in Fig. 1.

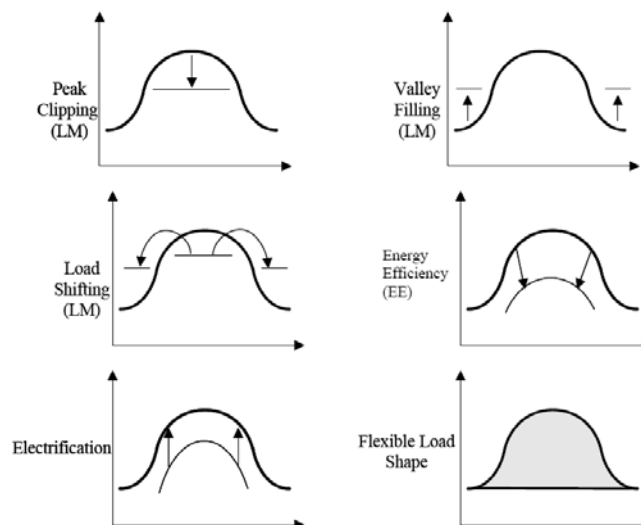

Figure 1. Loading alternatives on the DSM activities (CRA, 2005)

As in Fig.1, peak clipping, valley filling, and load shifting are classified as load management purposes. Energy efficiency includes reduction of all energy use and is also known as energy conservation. Technically, they are different because the level of energy services is maintained by means of energy efficiency but decreased in energy conservation. Electrification includes the construction of the load over all hours and is often associated with a customer retention program from the perspective of energy providers. Meanwhile, the flexible load shape is intended to make the load curve is responsive to the reliability of load conditions (CRA, 2005).

3. RESEARCH METHODOLOGY

The system sizing as well as economic viability condition due to limitation of optimization scope is considered shall be enhanced by involving other approach such as load management under DSM so that the result can be further improved. The interesting findings that may be obtained from this research are what type of loading that can generate the most optimal system sizing in terms of technical and economic point of view. In addition, what type of loading that the CO₂ reduction as well as the penetration rate of renewable energy resources can be maximally achieved.

3.1. Data collection and System Modeling

The assessment is conducted through simulation involving system’s technical and economic data. Optimization assessment on electricity supply is carried out using HOMER (Hybrid Optimization Model for Electric Renewable) software developed by the US National Renewable Energy Laboratory (Lambert et al, 2006). In addition, the weather condition such as average irradiation and wind speed is needed as the feed into the system energy resources. The system is then after modeled following several references necessarily to run the simulation. The necessary data gathered for overall assessment carried out in this research is comprised of:

3.1.1. Load profile

A hypothetical load profile for a sub-village used in this simulation is based on 50 households (Tanoto, 2011). Typical installed equipment and daily energy requirement for each household is shown in Table 1.

Table 1. Typical electric equipment installed in the rural household

Equipment	Power (Watt)	Daily usage (hour)	Energy (Watt hour/day)
Lamps			
• Terrace	10	10	100
• Room	30	6	180
• Kitchen	10	3	30
• Toilet	10	1	10
• Tape/radio	30	4	120
TV/VCR	70	3	210
Total			650

The coincident factor is considered equal to 1 so that possible system’s maximum peak load can be captured. The approximate typical load profile for base case and different

loading profile with respect to 30% load profile variation is given in Fig.2 and Fig.3, respectively.

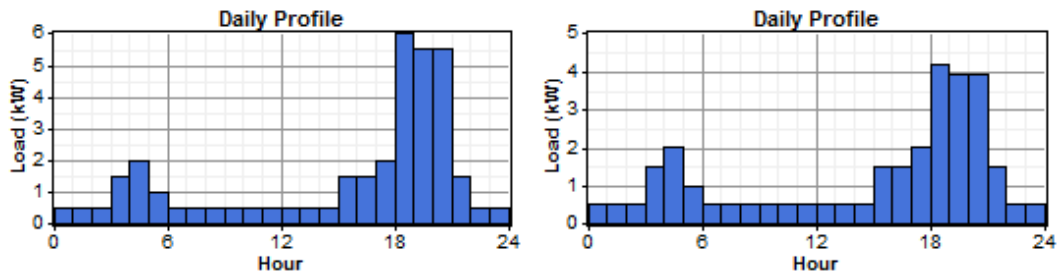

Figure 2. Typical daily load profile for: (a) base case, (b) and 30% peak clipping

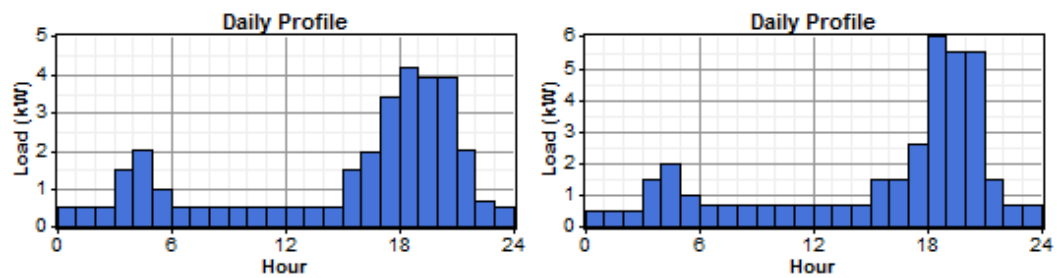

Figure 3. Daily load profile for: (a) 30% load shifting, and (b) 30% valley filling

3.1.2. Renewable energy data

The observation site is Baa region in Rote Ndao district of East Nusa Tenggara. The site is geographically located on 10°50’ South latitude and 123°0’ East longitude. The weather data as shown in table 2 are gathering from NASA since there is no measurement available from the nearby meteorology station.

Table 2. Weather condition in Baa, Rote Ndao district

Month	Daily radiation (kWh/m ² /day)	Clearness index	Wind speed (m/s)*
January	5.87	0.532	4.91
February	5.73	0.524	5.13
March	6.25	0.598	3.82
April	6.35	0.667	4.03
May	5.93	0.695	5.00
June	5.52	0.690	5.47
July	5.76	0.701	5.00
August	6.53	0.721	4.19
September	7.21	0.718	3.25
October	7.54	0.704	2.72
November	7.25	0.661	2.82
December	6.41	0.582	3.98

*)Wind speed is measured on 10 meters high and as an average of 10 years satellite measurement.

3.1.3. System modeling and configuration

The hybrid power generation system is connected to the household having a total base case energy requirement of 32.5 kWh/day with 6 kW peak load demand. Considering 5% standard deviation in the sequence of daily averages gives the peak load to be 6.5 kW. The base case loading is then changed following to the loading variation scheme as mentioned earlier. A complete configuration containing full technology option considered for hybrid system is shown in Fig. 4.

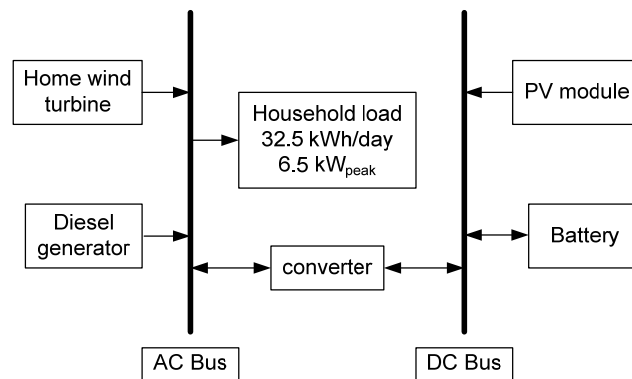

Figure 4. System configuration in complete option

The hybrid system major equipment is presented in Table 3. The sizing along with the technical and economic data is used as reference for simulation purpose.

Tabel 3. System technical and economic specification data (Tanoto, 2011)

Description	Data
PV Module	
Rated output	135 Watt <i>peak</i>
Maximum voltage	17.7 V
Maximum current	7.63 A
Open circuit voltage	22.1 V
Short circuit current	8.37 A
Maximum system voltage	600 V DC
De-rating factor (incl. charge controller)	85%
Initial cost	USD 530
Replacement cost	USD 480
Service life	25 years
Battery	
Nominal voltage	12 V
Nominal capacity	200 Ah, 2.4 kWh
State of Charge (SOC)	40%
Initial cost	USD 480
Replacement cost	USD 380
Operational and maintenance cost	USD 4/year
Service life	4 year

Table 3. System technical and economic specification data (Continue)

Description	Data
Charge controller	
Maximum current	20 A
Wind turbine	
Rated power	1.8 kW
Nominal voltage	220 Volt AC
Nominal capacity per month	400 kWh, 5.4 m/s
Starting speed	3.5 m/s
Initial cost	USD 4,000
Replacement cost	USD 3,000
Service life	15 years
Converter	
Inverter and rectifier's efficiency	90% and 85%
Initial cost	USD 730/kW
Replacement cost	USD 730/kW
Diesel generator	
Estimated operating hour	15,000 hours
Minimum load ratio	30%
Fuel curve intercept	0.05liter/hour/kW rated
Fuel curve slope	0.33 liter/hour/kW output
Amount of CO ₂	2.6 kg/liter
Initial cost	USD 240/kW
Replacement cost	USD 200
Hourly maintenance cost	USD 0.04
System's economic	
Annual inflation rate	8%
Fuel cost	USD 0.8
System initial cost	USD 2,000

4. SIMULATION RESULT AND DISCUSSION

HOMER simulates system operational based on the energy balance principle. It counts every hour for 8,760 hours a year. Electric demand in the hour is compared to the energy that the system can supply in that hour and the flow of energy to and from each component of the system is calculated to determine whether it can meet the electric demand under the specified conditions, and estimates the cost of installing and operating the system over the lifetime of the project. The final objective of the simulation is to identify a configuration among a set of systems that meets the desired system reliability requirements with the lowest energy cost. To capture system loading changing, each loading type is simulated separately based on the desired load profile.

Considering the finding from the previous work, that the lowest cost of energy is obtained from the system supplied by AC voltage rather than that with DC, the simulation conducted in this research is run with AC voltage. In this research, the forced constraint includes annual power shortage which is set to be zero. Optimum component sizing for each loading type is presented in Table 3. Meanwhile, economic implication resulted from the simulation is shown in Table 4.

Table 4. Optimum sizing and cost of energy for different loading condition

Wind speed (m/s)	PV (kW)	Wind turbine (pcs)	Battery (pcs)	Converter (kW)	Diesel Generator (kW)	% RE fraction	Cost of Energy (USD/kWh)
Base case loading							
3.5	1	1	3	2	5	0.26	0.52
4	1	2	3	2	5	0.43	0.50
5	0.5	2	3	2	5	0.53	0.44
5.5	0.5	2	3	2	5	0.60	0.42
30% Peak clipping							
3.5	1	1	3	2	4	0.26	0.50
4	1	2	3	2	4	0.43	0.48
5	0.5	2	3	2	4	0.54	0.43
5.5	0.5	2	3	2	3.5	0.60	0.40
30% Load shifting							
3.5	1	0	3	1	4	0.16	0.48
4	1	1	3	1	4	0.31	0.47
5	0.5	2	3	2	3.5	0.54	0.42
5.5	0.5	3	2	2	3.5	0.73	0.39
30% Valley filling							
3.5	1.5	0	3	1	6	0.20	0.51
4	1.5	2	4	2	5	0.44	0.49
5	1	3	4	2	5	0.65	0.44
5.5	1	3	3	2	5	0.70	0.41

From Table 4, it can be inferred that the benefit of peak clipping in terms of renewable energy fraction and cost of energy is not significant compared to that achieved by base case loading, except for the result obtained by load shifting, which is USD 0.39/kWh. In addition, the highest renewable energy fraction is achieved by load shifting as well with 73% for the fastest wind speed. Moreover, load management peak clipping method may not give the desired improvement on renewable energy fraction as well as reduction on cost of energy due to insignificant changing in hybrid system's sizing, except a slightly reduction in generator fuel cost.

5. CONCLUSION

In this research, the effect of load management under DSM principle over stand-alone hybrid distributed generation feeding a community in the rural area. The main finding includes the benefit of load shifting over other loading patterns. The grid connected-hybrid system shall be observed in the future study to provide relevant comparison to the current findings.

REFERENCES

- Haidar, A.M.A., et.al. *Optimal Configuration Assessment of Renewable Energy in Malaysia*. Renewable Energy, vol. 36: 881-888, 2010.
- Hongxing, Y., et.al. *Optimal design and techno-economic analysis of a hybrid solar wind power generation system*. Applied Energy, vol. 86: 163–169, 2009.

- Gellings, C.W. dan Chamberlin, J.G. *Demand-Side Management: Concepts and Methods*. Fairmont Press Inc, 1987.
- Surapong, C. *Lecture Notes of Demand Side Management*", Asian Institute of Technology, Bangkok, Thailand, 2000.
- Charles River Associates (CRA). *Primer on Demand Side Management with emphasis on price-responsive programs*. Oakland, California, 2005.
- Lambert T., et.al. *Micropower system modeling with HOMER, integration of alternative source of energy*. Available at:
<http://www.pspb.org/e21/media/HOMERModelingInformation.pdf>. Downloaded on 24 Aug 2009.
- Tanoto, Yusak. *Optimization Assessment of Off-Grid Hybrid Distributed Generation System for Remote Sub-Village-Sized*. Proceeding SITIA ITS Surabaya, 2011.